

**Detroit Speed**  
**Delrin™ Leaf Spring Bushing Kit with Shackles**  
**1967-81 Camaro/Firebird, 1968-74 Nova**  
**P/N: 041502DS**

Our Delrin™ Leaf Spring Bushing Kits provide the ultimate handling performance for leaf spring applications by reducing bushing compliance. Our bushings also offset the leaf springs inboard to gain more clearance with your DSE Mini-Tub Kit.

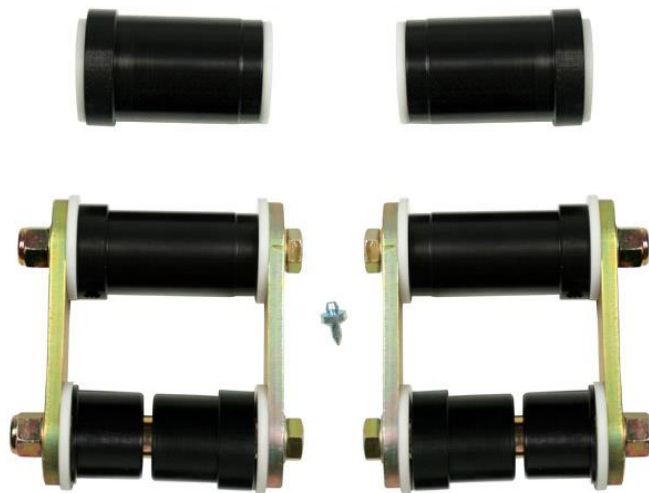

**Figure 1 - Assembled Bushings, Washers, and Shackles**

Item	Component	Quantity
1	Leaf Spring Crush Tube	6
2	Delrin™ Leaf Spring Sleeve Bushing	6
3	Delrin™ Leaf Spring Thrust Bearing	12
4	Leaf Spring Aluminum Front Bushing	2
5	Leaf Spring Aluminum Rear Bushing	2
6	Delrin™ Upper Leaf Spring Rear Outer Bushings	2
7	Delrin™ Upper Leaf Spring Rear Inner Bushings	2
8	Delrin™ Lower Leaf Spring Rear Bushings	2
9	Rear Leaf Spring Shackle	4
10	1/2"-20 x 5" L Grade 8 Bolt	4
11	1/2"-20 Grade 8 Nylock Nut	4
12	1/2" AN Washer	8
13	Loctite Retaining Compound - 0.5mL	1
14	Flush Zerk Fitting Nozzle	1
15	Instructions	1

## Front Leaf Spring Bushings

1. After pressing out your stock bushings (if applicable), install the bushings as shown in Figure 2. Install the grease fittings facing down to ensure easy access for greasing.
2. Position the thick side of the bushing on the outboard side of the leaf spring to provide maximum tire to spring clearance. Grease the bushings before use.

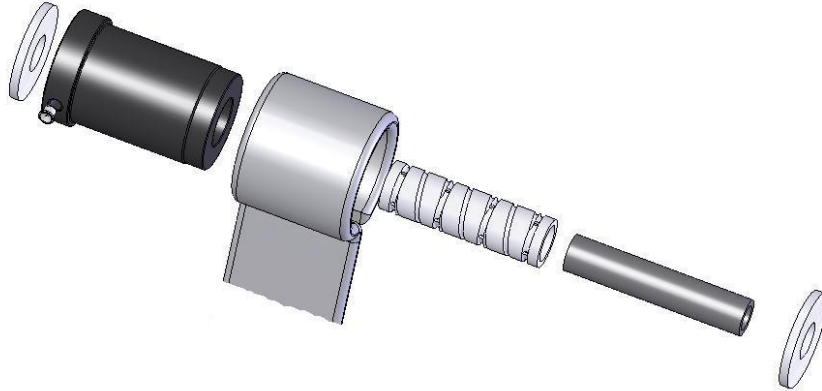

Figure 2 – Front Leaf Spring Bushing Assembly

## Rear Leaf Spring Bushings

1. After removing your stock shackles and pressing out your stock bushings (if applicable), ensure that the bushings are oriented in the shackles as follows.
  - a. The upper, two-piece bushings should be installed with the grease fittings facing toward the inside and front of the vehicle.
  - b. The lower, one-piece bushings should be installed with the grease fittings facing down and toward the outside of the vehicle.
2. Correct bushing configuration can be seen in Figure 3. This configuration is correct for standard and offset shackles. The included Delrin™ washers should be installed between the bushing and the shackle at each contact point as seen in Figure 1.

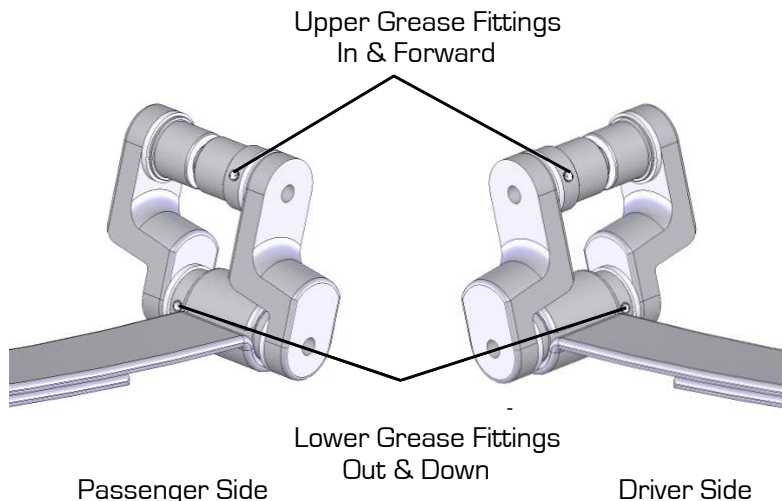

Figure 3 – Delrin Bushing Positioning (Normal or Offset Shackles)

3. Installing the bushings can be made easier by pre-lubricating the bushings before pressing them into the springs and shackle mounts. The provided retaining compound can be used for this step.
4. Once all the leaf spring and frame bushings are installed and crush sleeves are in place, install the front leaf spring into the vehicle using your factory hardware and tighten.
5. Move to the rear leaf springs; install the rear shackles and 1/2"-20 x 5" L Hex Head bolts to mount the leaf springs to the frame using the 1/2" Nylock nuts and AN washers. Install the bolts from the outside of the frame rail so that your Nylock nuts will be on the inside closest to the fuel tank. [See Figure 4]

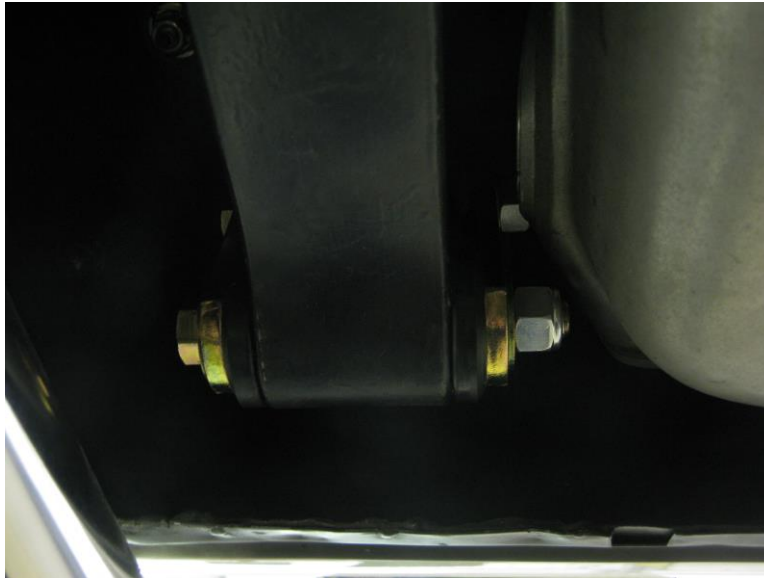

Figure 4 – Rear Leaf Spring Shackles Installed

6. Once the leaf springs are installed torque all fasteners to 75 ft-lbs.
7. After installation, the bushings should be lubricated thoroughly and checked for adequate lubrication from time to time.

If you have any questions before or during the installation of this product, please contact Detroit Speed at [tech@detroitsspeed.com](mailto:tech@detroitsspeed.com) or 704.662.3272