

Detroit Speed
Front Coilover Conversion Kit
1993-2002 Camaro/Firebird
P/N: 030340DS, 030340-SDS & 030340-DDS

The Detroit Speed Front Coilover Conversion Kit is a 100% direct bolt-on kit that provides excellent ride quality along with ride height adjustability of a coilover shock and spring for your 1993-2002 Camaro/Firebird. The kit uses an aluminum body JRi coilover shock featuring "Detroit Tuned" shock valving. This kit allows spring changes to be performed without needing to remove the front wheels.



Item	Part Description	Quantity
1	Lower Shock Mount Welded Assembly	2
2	Upper Shock Mount Welded Assembly, LH & RH	2
3	Coilover Shock	2
4	Coilover Spring	2
5	Steel Bushing - 3/4" OD x 1/2" ID x 5/8" L	4
6	Detroit Speed/JRi Spanner Tool	1
7	Instructions	1

Hardware Checklist – Universal Rear Suspension Kit			
Part Number	Description	Quantity	Check
200042	Coilover Conversion Hardware Kit	1	
980114FS	M10-1.5 x 30mm Flange Hex Bolt	8	
980117FS	M10-1.5 x 70mm Flange Hex Bolt	4	
960067FS	M10 x 1.5 Prevailing Torque Flange Locknut	12	
980026FS	1/2"-20 x 2-1/2" L Hex Head Bolt	4	
960004FS	1/2"-20 Nylock Nut	4	
970019FS	1/2" AN Washer	4	

Fastener Torque Specifications		
Application	Torque (lbf-ft)	Threads
M10 Lower Shock Mount Bolts	45	
M10 Upper Shock Mount Bolts	45	
1/2"-20 Coilover Shock Bolts	60	Anti-Seize

NOTE: Detroit Speed recommends the Torrington Bearing Set (P/N: 031062DS) to help when adjusting the ride height on your vehicle (Figure 1)



Figure 1 – Torrington Bearing Set

Installation Instructions

1. To begin installation, chock the rear wheels and loosen the front lug nuts. Raise and support the front of the vehicle with jack stands. Remove the front wheels.
2. Disconnect the front sway bar from the lower control arm. Remove the brake caliper brackets from the spindle and remove the caliper/bracket assemblies. Support the caliper bracket assemblies underneath the vehicle. Remove the rotors from the hubs.
3. To remove the factory shock/spring assembly from the vehicle, start by removing the lower shock bolts from the lower control arms.
4. Next, remove the two 15mm nuts and two bolts from the studs at the upper shock mounts on both sides of the vehicle. On the driver side, you will need to use a T50 Torx socket on the bolts under the brake master cylinder (Figure 2 on the next page).



Figure 2 – Remove Torx Bolts

NOTE: You will need to remove the brake master cylinder from the booster to gain access to the T50 Torx bolts. You can remove the two nuts holding the master cylinder to the booster and then loosen the two nuts holding the ABS pump in the bracket (Figure 3). You do not need to remove the brake lines, but be careful not to kink them in the process. Lift the ABS pump up and set these two items aside in order to gain access to remove the T50 Torx bolts.

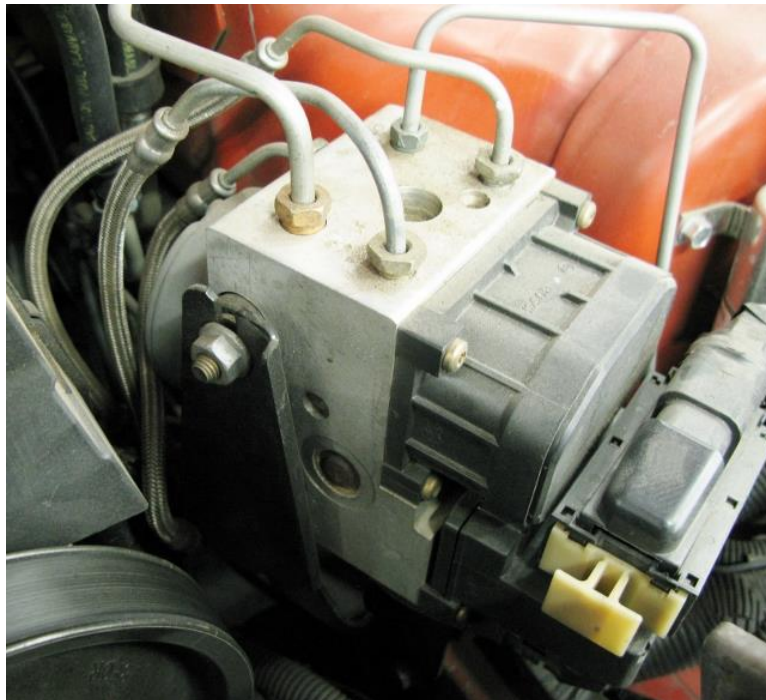

Figure 3 – Loosen ABS Pump from Bracket

5. To remove the shock assembly, push down on the lower control arm as you pull down on the shock and spring assembly to drop the upper shock mount studs out of the vehicle (Figure 4 on the next page). The upper control arm will come out with the assembly so you will need to rotate the upper control arm towards the back of the vehicle as you remove the shock assembly.



Figure 4 - Drop Upper Control Arm Down

6. Once the shock and spring assembly has been removed, position the upper control arm back underneath the vehicle using a floor jack under the lower control arm.
7. Place the provided M10-1.5 x 30mm flange hex bolts through the top of the shock structure from the engine bay (Figure 5). Raise the floor jack under the lower control arm and position the upper control arm mount so that the bolts pass through the upper control arm mount.



Figure 5 - M10-1.5 x 30mm Flange Hex Bolts

8. Next, install the Detroit Speed upper shock mount under the upper control arm mount.
NOTE: There is a left and right hand part that will only go on one way so make sure you install the correct one. The welded shock spacer should be towards the front of the vehicle.

9. Thread the provided M10-1.5 locknuts onto the bolts and tighten (Figure 6). Torque the fasteners to 45 lbf-ft.



Figure 6 - Install Upper Shock Mount

10. Install the Detroit Speed lower shock mount assemblies onto the lower control arms. They will bolt into the same location as the factory lower shock bolts. Use the provided M10-1.5 x 65mm flange hex bolts and locknuts to attach the lower shock mounts to the vehicle (Figure 7). Torque the fasteners to 45 lbf-ft. Repeat steps 5 through 10 for the opposite side of the vehicle.



Figure 7 - Install Lower Shock Mount

11. Next, install the coilover springs onto the shocks.

12. Remove the upper spring seat from the retaining ring by gently using a rubber hammer to move it down off the shock mount (Figure 8). Remove the retaining ring from the shock mount and pass the upper spring seat over the shock mount (Figure 9).



Figure 8 – Removing the Upper Spring Seat



Figure 9 – Upper Spring Seat & Retaining Ring

13. Thread the spanner nut all the way to the bottom of the coilover shocks. Slide the coilover springs over the end of the shocks. Install the upper spring seat back over the end of the shock and re-install the retaining ring back onto the shock mount. Press the upper spring seat up onto the retaining ring so it locks in place.
14. Next, install the coilover shock with the body side up into the upper shock mount. Position the body side of the shock into the upper shock mount and install one of the provided 1/2"-20 x 2-1/2" L hex head bolt and washer through the upper shock (Figure 10). **NOTE:** Make sure the shock valve is pointing outward from the vehicle.



Figure 10 – Install Upper Shock Bolt

15. Apply anti-seize to the threads and install one of the provided steel bushings and 1/2"-20 Nylock nut onto the upper shock bolt. Torque to 60 lbf-ft.

16. Next, position the lower control arm to locate the end of the shock to the lower shock mount and install one of the provided 1/2"-20 x 2-1/2" L hex head bolt and washer through the lower shock mount (Figure 11). **NOTE:** If you have double adjustable shocks, make sure the adjustment window is towards the rear of the vehicle.



Figure 11 - Install Lower Shock Bolt

17. Apply anti-seize to the threads and install one of the provided steel bushings and 1/2"-20 Nylock nut onto the lower shock bolt. Torque to 60 lbf-ft. Repeat steps 16 through 19 for the opposite side of the vehicle (Figure 12).



Figure 12 - Installed Coilover Kit

18. Re-install the sway bar end link to the lower control arm and torque to 53 lbf-ft. Re-install the rotors on the hubs as well as the caliper bracket assemblies to the spindles. Torque the caliper bracket bolts to 74 lbf-ft.

19. Install the front wheels and torque to the factory specifications. With the vehicle on the ground, adjust the coilover shocks to the desired ride height.

WARNING: DO NOT ADJUST THE COILOVER ADJUSTING NUT WITHOUT THE VEHICLE RAISED OFF THE GROUND TO REMOVE THE WEIGHT OFF THE COILOVER SHOCKS. FAILURE TO FOLLOW THIS PROCEDURE WILL RESULT IN DAMAGED THREADS ON THE SHOCK BODY THAT CANNOT BE WARRANTIED.

20. Before adjusting the ride height, DSE recommends cleaning the threads of the shock. Once the threads are clean, DSE recommends applying dry bicycle chain lube to the threads of the shock body before adjusting the spanner nut and compressing the coilover spring. Allow the chain lube to dry before adjusting the spanner nut. If you have the non-adjustable shocks, the spanner nut has a soft tip set screw that will need to be tightened before the vehicle is driven. **NOTE:** If the installer is not the owner/driver of the vehicle, make sure the owner is aware of this procedure.

21. Detroit Speed does include a spanner tool (P/N: 031060DS) to adjust ride height however if you have the adjustable coilover shocks, Detroit Speed does offer an adjustment tool available as P/N: 031061DS if needed. A photo can be seen in Figure 13.



Figure 13 - Detroit Speed Spanner & Adjustment Tool

22. If the Single Adjustable, Double Adjustable or the Double Adjustable Remove Canister Coilover shocks were purchased as an upgrade, refer to the following information for adjustment procedures.

Detroit Speed Single Adjustable Shock Applications

To change from the recommended “Detroit Tuned” valving, adjustments can be made independently to the rebound setting. The rebound is controlled by the knob at the upper shock mount (Shock is mounted body side down). The knob rotates clockwise (+) to increase the damping and counterclockwise (-) to decrease the damping. Refer to Figure 14a on the next page.



Figure 14a - Detroit Speed Single Adjustable Shock

To return to the Detroit Speed recommended settings, turn the knob clockwise (+) to full damping. Once at full damping, turn counterclockwise (-) to reach the recommended settings. Refer to Figure 14b for the rebound settings.

Rebound (Shaft Knob)..... 15 Open (counterclockwise, -)

Figure 14b - Detroit Speed Recommended Settings

Adjuster Operation

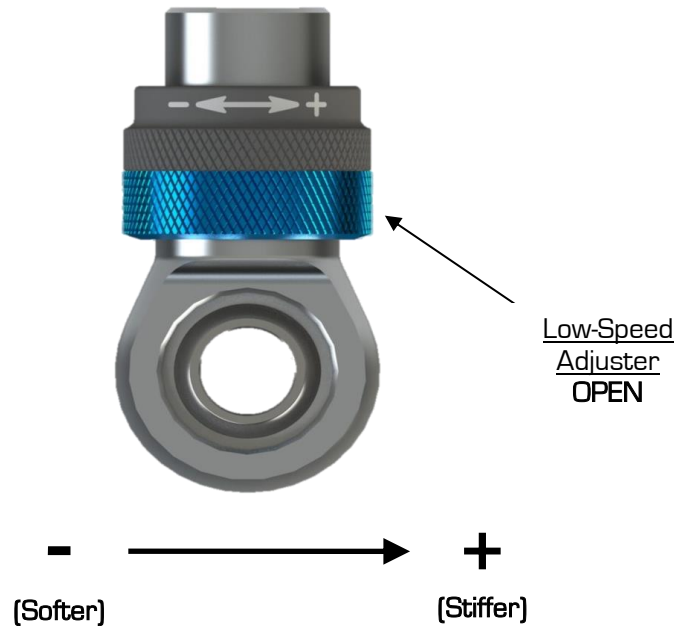

- **Adjuster (60-64 Clicks)**

The low-speed adjuster is a “clicker” style adjuster meaning that its adjustment is measured by detents located inside the blue adjuster knob. There are 16 clicks per 1 revolution of the knob. It uses a right-hand thread in its operation which means as you increase low-speed, the adjuster will move up on the eyelet. The recommended change for an adjustment is 8 clicks at a time. The low-speed adjuster’s reference position is **full stiff** (closed, or all the way up) and referred to -0 (-0 = full stiff, -64 = full soft).

- **Tuning Notes**

- **Racetrack**

- For more grip, soften the damping.
 - For increased platform control, stiffen the damping.

- **Street**

- For a more comfortable ride, soften the damping

***DO NOT FORCE KNOB WHEN IT STOPS TURNING, YOU MAY DAMAGE THE ADJUSTER AND INTERNAL HARDWARE**

Detroit Speed Double Adjustable Shock Applications

To change from the recommended “Detroit Tuned” valving, adjustments can be made independently to both the high and low speed settings. The rebound is controlled by the sweepers at the upper shock mount. The sweepers rotate clockwise (+) to increase the damping and counterclockwise (-) to decrease the damping. The sweepers can be seen in Figure 15a on the next page.



Figure 17a - Detroit Speed Double Adjustable Shock

When adjusting the low speed rebound start at full (+) position, when adjusting the high speed rebound start at full (-) position. To return to the Detroit Speed recommended settings turn the sweeper clockwise (+) to full damping for the low-speed setting, and counterclockwise (-) to full damping for the high-speed setting. Once at full damping, turn counterclockwise (-) for the low speed setting, and clockwise (+) for the high speed setting to reach the recommended settings. Refer to Figure 15b for recommended settings.

Low Speed Rebound (Sweeper)..... 15 sweeps (counterclockwise, -)
 High Speed Rebound (Sweeper)..... 4 sweeps (clockwise, +)

Figure 15b - Detroit Speed Recommended Settings

Adjuster Operation

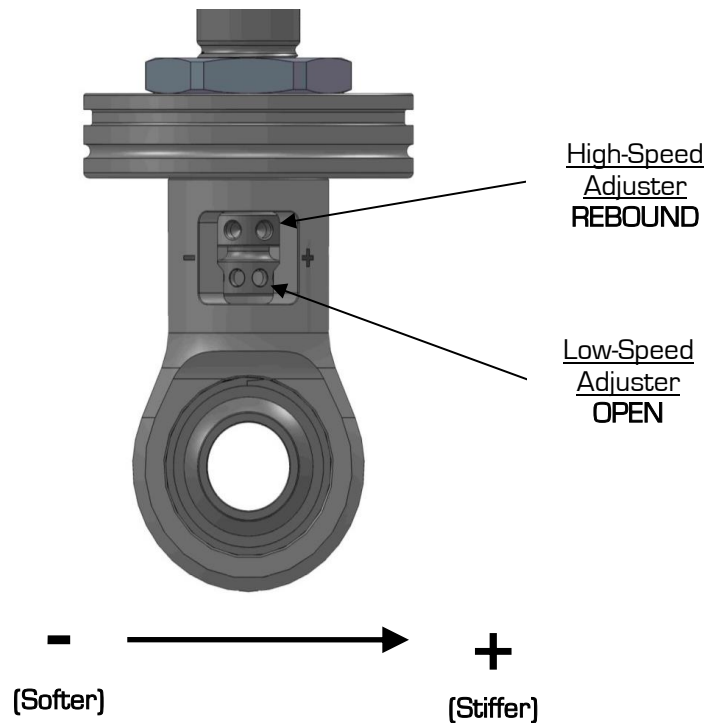

- **High-Speed Adjuster (12 Sweeps)**

The high-speed adjuster is a “sweep” style adjuster meaning that its adjustment is measured by the location of the adjuster in the eyelet window. It uses a left-hand thread in its operation which means; as you increase high-speed, the adjuster will move down in the window*. The high-speed adjuster’s reference position is **full soft** and referred to as +0 (+0 = full soft, +12 = full stiff).

- **Low-Speed Adjuster (25 Clicks)**

The low-speed adjuster is a “clicker” style adjuster meaning that its adjustment is measured by detent grooves located inside the high-speed shaft. It uses a right-hand thread in its operation which means; as you increase low-speed, the adjuster will move up in the window. The low-speed adjuster’s reference position is **full stiff** and referred to -0 (-0 = full stiff, -25 = full soft).

**The low-speed adjustment does not change when adjusting the high-speed.*

23. Once the car is adjusted to the desired ride height, have an alignment by a professional alignment shop performed at this point.

If you have any questions before or during the installation of this product, please contact Detroit Speed at tech@detroitsspeed.com or 704.662.3272